

# System OWAcliq 15/16" Intermediate Duty



OWAcliq 15/16" Intermediate Duty  
exposed

OWAlifetime collection

**OWA**

# System OWAccliq 15/16" Intermediate Duty | Exposed

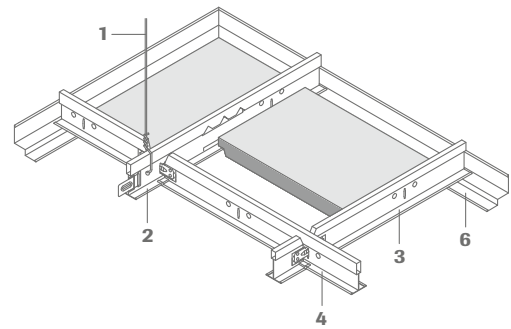
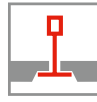
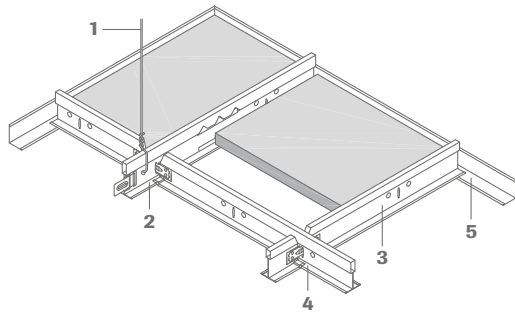

## Section dimensions:

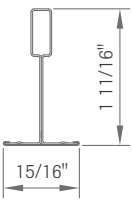

Main tee  
cliq-15/16-MR-ID

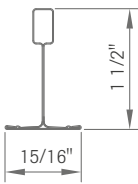

Cross tee  
cliq-15/16-CT-ID long

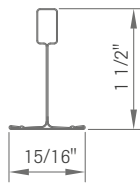

Cross tee  
cliq-15/16-CT-ID short

- 1 Wire (by client)
- 2 Main tee cliq-15/16-MR-ID, slotted every 6"
- 3 Cross tee cliq-15/16-CT-ID, length 2'
- 4 Cross tee cliq-15/16-CT-ID, length 4'
- 5 Wall angle no. 51/24G
- 6 Shadow wall angle no. 50/15
- 7 Contura block no. 42/24

## Cross-section of system with SQ tile:

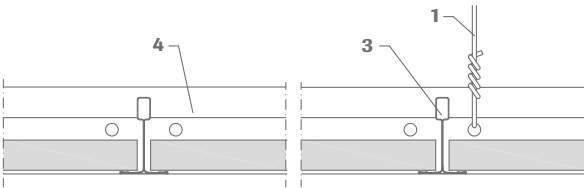

## Cross-section of system with RE tile:

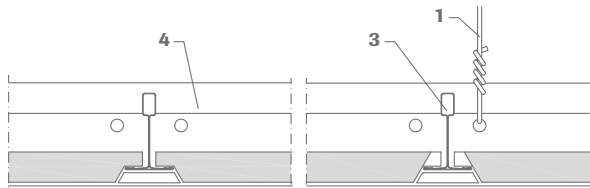

## Section of system with SQ tile:

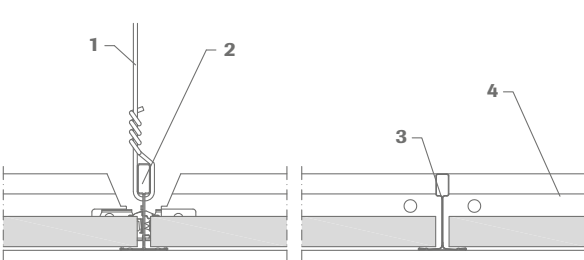

## Section of system with RE tile:

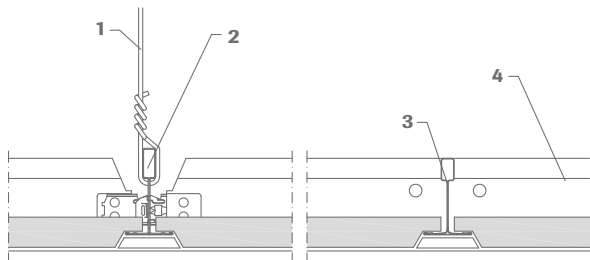

## Technical data | Mineral tiles

### Module sizes

24" x 24", 48" x 24"

### Edge details



### Reaction to fire

OWAcoustic premium tiles: class 1 (ASTM E 84) | class A (ASTM E 1264)  
OWAconstruct suspension parts: class 1 (ASTM E 84) | class A (ASTM E 1264)

### Metal suspensions

All metal components listed are galvanized steel or white coated galvanized steel respectively.

### Duty Rating

Intermediate Duty (ASTM C 635)

### Suspension depth

3" - 4" (depending on the existing structural ceiling) for ease of panel removal 5" is recommended

## Wall angle details:

SQ tiles:

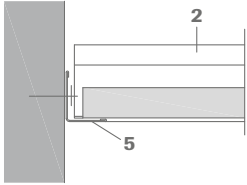

RE tiles:

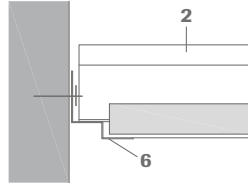

Wall angle no. 51/24G

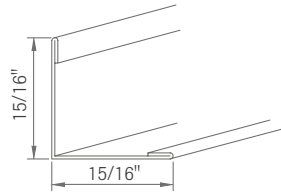

Shadow mold no. 50/15

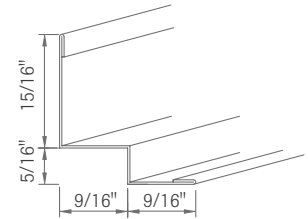

For more information about installation, see [OWA-Installation Guide 9801 e](#).

## Installation examples:

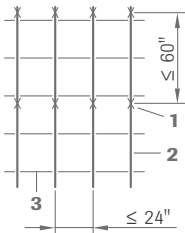

Module 24" x 24"

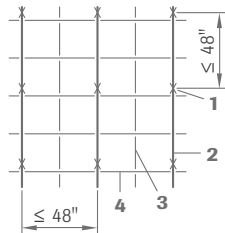

Module 24" x 24"

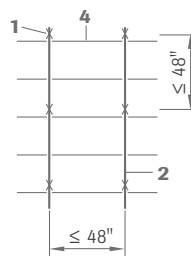

Module 48" x 24"

## Advantages at a glance:

- easy installation of main tees and cross tees
- cross tees simply snap into place
- audible "click" confirms location
- load-bearing capacity tested in accordance with European and US standards
- proven OWA quality
- available worldwide via the global OWA distribution network
- meets LEED® standard regarding recyclability
- meets criteria for seismic design category C in accordance with ASTM E580 IBC with requirements according to ASTM E580/CISCA seismic construction handbook
- can be used with other panel products
- Intermediate Duty (ASTM C 635)

	Description/rating per ASTM C-635	Pcs/ctn	LF/ctn	Weight lbs/ctn	Ctns/pallet
cliq-15/16-MR-ID	12' main tee, (Cliq system), 15/16", white	20	240	59	42
cliq-15/16-CT-ID	4' cross tee, 15/16", cliq end, white	60	240	55	50
cliq-15/16-CT-ID	2' cross tee, 15/16", cliq end, white	60	120	28	80
51/24G	12' wall angle, 15/16" x 15/16", white	30	360	48	60
50/15	12' shadow mold, 15/16" x 9/16" x 5/16" x 9/16", white	35	420	76	33



**Material requirements per ft<sup>2</sup>** (approximations):  
Module sizes in inches

No.	Description	24" x 24"	48" x 24"
	Wire	0.06 piece	0.06 piece
cliq-15/16-MR-ID	Main tee	0.25 LF	0.25 LF
cliq-15/16-CT-ID	Cross tee short	0.25 LF	-
cliq-15/16-CT-ID	Cross tee long	0.50 LF	0.50 LF
51/24G	Wall angle (SQ tiles)	Depending on room size and shape	
50/15	Shadow wall angle (RE tiles)	Depending on room size and shape	
42/24	Contura block	Depending on room size and shape	

**Weight per ft<sup>2</sup>:**

	24" x 24"	48" x 24"
Suspension system approx.	0.24 lb/ft <sup>2</sup>	0.18 lb/ft <sup>2</sup>
Tile 5/8" approx.	0.92 lb/ft <sup>2</sup>	0.92 lb/ft <sup>2</sup>

**System description: OWAconstruct system  
OWAcliq 15/16" Intermediate Duty**

**Quality requirements for mineral tiles:**

OWAacoustic mineral tiles firmly bound with a primer coat on both sides. The tile is free from asbestos. No formaldehyde is added in the manufacturing process of the mineral tiles. The mineral wool used for the manufacture of the tile is bio-soluble. The criteria for non-classification as a carcinogenic substance in accordance with the Chemicals Prohibition Ordinance (Section 1 Appendix, Paragraph 23 biopersistent fibres) are met and guaranteed by the RAL seal of approval for mineral wool. Verification of fitness for use according to EU CPR: CE marking and Declaration of Performance (DoP).

Mineral tiles accordance with EN 13964 and DIN 18177:

Air permeability class PM 1  
Formaldehyde class FH 1  
Emission of VOC TVOC 1

**Installation** should be carried out in accordance with the information contained in system leaflet OWAcliq 15/16" us and [OWA-Installation Guide 9801 e](#). All components are CE labeled.

**Component list:**

Wire (by client)  
Main tee cliq-15/16-MR-ID  
Cross tee short cliq-15/16-CT-ID  
Cross tee long cliq-15/16-CT-ID  
OWAconstruct wall angle no. 51/24G  
OWAconstruct shadow wall angle no. 50/15  
Contura block no. 42/24

**Green building materials: OWAconstruct grid system scores according to LEED®**

This OWAconstruct suspension system is designed and produced by OWA and meets the current LEED® standards. As an environmentally friendly grid the materials used for production are completely recyclable.

OWAconstruct is manufactured in accordance with the European standard EN 13964 and is 100% recyclable.

In buildings trying to achieve LEED® accreditation, the recycled content of the building materials used must be at least 20% (post-industrial + post-consumer). Where this figure is exceeded the maximum number of points according to the LEED® criteria can be attained.

OWA continually strive to achieve the optimum balance between the use of recycled materials, conservation of resources and the production of high quality performance products. We have now increased the post consumer recycled content of our grid to 23%.

When calculated in accordance with LEED® criteria the post industrial recycled content is now 27%.

The OWAconstruct grid production is continually monitored by both internal and external checks and the increase in recycled content has been achieved without sacrificing quality or performance.

\* Post-industrial is the industrial waste from production. Post-consumer represents the end of product life, where the consumer can longer use the product for its intended use.



Certified Management Systems

**Product warranties**

The information provided in this leaflet is based on the standards and data available at the time of publication. Any performance, warranties or guarantees provided, expressed or implied, are subject to the exclusive use of OWA components and the installation of those components in accordance with our recommendations. Failure to adhere to these conditions will result in the invalidation of any performance claims, warranties or guarantees and rejection of any liability. OWA reserves the right to make any technical improvements to the products, systems or services without prior notice. **All goods and services are supplied in accordance with our current Terms and Conditions of Sale.** Subject to alterations!



The information in this brochure is up-to-date at the time of publication. Subject to alterations. Please contact our OWAconsult team for specific advice. Our experts will be happy to answer your questions using the following contact details:  
tel: +49 9373 201-444 or e-mail: [info@owaconsult.de](mailto:info@owaconsult.de)

**OWA USA Corporation**  
245 N Highland Ave, Suite 230-715, Atlanta, GA 30307, USA  
(800) 487-4308 | [usa@owa-ceilings.com](mailto:usa@owa-ceilings.com)  
[www.owa-ceilings.com](http://www.owa-ceilings.com)

Brochure  
**OWAcliq 15/16"-ID us**  
012600